

Fluorescence depolarization and contact angle investigation of dynamic and static interfacial tension of liquid crystal display materials

Cristina M. Quintella,^{a,*} Ângelo M.V. Lima,^a Cristiane C. Gonçalves,^a Yuji N. Watanabe,^a
Alaíde P. Mammana,^b Marcos A. Schreiner,^b Iuri Pepe,^c and Ângela A. Pizzo^{d,1}

^a Instituto de Química, Universidade Federal da Bahia, Campus de Ondina, 40170-290 Salvador, BA, Brazil

^b Centro de Pesquisas Renato Archer—CenPRA, Rod. D. Pedro I, km 143.6, Amarais, 13082-120 Campinas, Brazil

^c Instituto de Física, Universidade Federal da Bahia, Brazil/LPCC, College de France, Paris, France

^d Lab. Aplicações Tecnológicas de Plasma, Instituto de Física, Universidade de São Paulo, Brazil

Received 16 May 2002; accepted 20 February 2003

Abstract

Interfacial interactions control two processes empirically known to be critical for molecular anchoring in twisted nematic liquid crystal displays technology (TN-LCDs): surface treatment and filling procedure. Static and dynamical interfacial tensions (Γ_{SL}) between liquids and several substrates with similar roughness were observed respectively by contact angle (θ_c) of sessile drops and by fluorescence depolarization of thin liquid films flowing at high velocity. Γ_{SL} decreased when glass was coated with tin dioxide and increased with polyvinyl alcohol (PVA) deposition. Drops were circular for all substrates except rubbed PVA, where they flowed spontaneously along the rubbing direction, reaching an oblong form that had θ_c parallel and perpendicular to the rubbing direction respectively greater and smaller than θ_c for nonrubbed PVA. This is attributed to polar group alignment generating an asymmetric Γ_{SL} distribution with nanometric preferential direction, inducing a capillary-like flow. Polarization and anisotropy maps for high-velocity flow parallel to the PVA rubbing direction showed an increase in the net alignment of molecular domains and a widening of the region where it occurred. This is attributed to preferential anchoring in the downstream direction, instead of in several directions, as for nonrubbed PVA. This explains why filling direction is crucial for TN-LCDs homogeneous behavior.

© 2003 Elsevier Science (USA). All rights reserved.

Keywords: Micro fluid dynamics; Intermolecular forces; Fluorescence depolarization; PLF; Interfacial tension; Dynamic interactions; Polyvinyl alcohol; Rubbed polymer; Liquid crystal displays technology; Liquid flow

1. Introduction

Among several technologies of information displays, liquid crystal (LC) display stands out [1], due to the following advantages: it is planar and thin and it has a low power consumption, a simple manufacture process, large areas that can be processed simultaneously, and low production costs. Most LC displays (LCDs) use 90° twisted nematic crystals (TN-LCDs) that consist basically of cells formed by two treated glass sheets spaced at about 10 μm and filled with LCs. For small area displays, glass can be coated with a layer of high resistivity, tin dioxide, which is cheaper than indium

tin oxide and still easily printed. A polymer solution is deposited by spinning and the solvent is evaporated. Then the polymer is rubbed with organic fibers. Birefringence studies have shown that molecular chains and their polar groups align along the rubbing direction of the polymer layer [2].

LC molecules anchored at the solid interface produce the structure that generates the TN-LCDs electrooptical behavior. Empirically it is known that there are two critical processes responsible for molecular anchoring at determined directions and tilt angles: surface treatment (rubbing) of the polymeric layer and filling procedure.

Two different surface orientation mechanisms are known to be effective in aligning bulk LC. One consists of a long-range process via elastic interactions where LC molecules align themselves along the substrate grooves in order to minimize bulk elastic energy [3]. It occurs when polar anchoring energy is low, as in SiO_x , silanes, and polymers

* Corresponding author.

E-mail address: cristina@ufba.br (C.M. Quintella).

¹ Currently at Embalagem Zenith Ltda., R. Sta. Catarina, 641, Pq S. Jorge, São Paulo, CEP 03086-025, Brazil.

without polar groups [4,5]. The other is a short-range interaction between polymer chains (oriented by the rubbing) and the monolayer of LC adsorbed on the surface. This interaction depends on the chemical constitution of both liquid and substrate, since intermolecular forces will determine its strength. If it is strong, as in polymers with polar groups, the polar anchoring energy is high and LCs will be preferentially aligned by interacting directly with the polymer surface and this alignment is extended into the bulk, analogously to epitaxial growth [2].

Intermolecular forces at interfaces generate interfacial tensions that can be macroscopically evaluated by contact angles (θ_c) of small sessile drops [6]. For rough substrates and θ_c lower than 90° , the apparent angle is smaller than the true one. The Young equation relates these tensions to θ_c . When solid–vapor interfacial tension is much smaller than solid–liquid interfacial tension (Γ_{SL}), it is possible to consider the ratio of θ_c cosines as equal to the ratio of Γ_{SL} for the same liquid interacting with different substrates.

When a drop is moving along a solid surface at a very low speed, it is possible to determine advancing and receding angles, the former being larger and the latter smaller than the static θ_c . It was recently found that their difference, the hysteresis, can be strongly dependent on sorption that arises primarily from molecular interactions between liquid and solid, rather than from surface roughness [7,8]. Strong intermolecular forces, present at interfaces with polar groups, increase both the driving force and the resistance during slow dynamical wetting, depending on the spacing between putative adsorption sites [9]. Recently it was shown that drops can move at low speed due to continuous gradient wettability [10].

The contact angle method has never been used to characterize TN-LCDs interfaces, as far as the authors know.

The other empirically known process critical for TNs-LCDs is the filling procedure. It controls the first contact between liquid crystal and substrates, when the initial molecular anchoring takes place. It is known that high velocities intensify molecular effects as compared to hydrodynamic effects, thus becoming more susceptible to surface chemical constitution [6,11]. Intermolecular forces that occur while molecules are flowing on substrates cause the dynamical Γ_{SL} . Recently fluorescence depolarization was used to evaluate dynamic Γ_{SL} for monoethylene glycol with borosilicate and tin dioxide [12].

Usually fluorescence spectroscopy monitors samples at a single spot and without polarization resolution. For this application it is necessary not only to map flowing samples but also to determine the polarization of the fluorescence in order to assess intermolecular alignment within the flowing liquid. The technique used is polarized laser-induced fluorescence (PLF).

The principles of PLF have been discussed before [13,14]. Briefly, vertically polarized laser light excites fluorescent probes within a sample. Their absorption is proportional to the cosine squared of the angle between the molecular dipole

and the laser electric field. If the dipole is parallel to the longitudinal molecular axis (as for rhodamine, the probe used in this work), mainly nearly vertical molecules will absorb laser radiation. While excited, photoselected probes can rotate or not as a function of the mobility of the neighboring molecules and chemical environment. When fluorescence takes place, the light emitted is not 100% polarized, because the transition dipole moment of the probe depends on its molecular orientation. In PLF fluorescence emission is discriminated according to its polarization and compared with laser polarization.

Fluorescence depolarization can be interpreted either as a bidimensional phenomenon in terms of polarization (P) [13,14], or as a three-dimensional phenomenon in terms of anisotropy (r) [15,16]:

$$P = \frac{I_{\parallel} - I_{\perp}}{I_{\parallel} + I_{\perp}}, \quad r = \frac{I_{\parallel} - I_{\perp}}{I_{\parallel} + 2I_{\perp}}, \quad r = \frac{2P}{3 - P}.$$

The high velocity imposed on the liquid flow causes a preferential molecular orientation in the downstream direction that is photoselected by the laser [12]. Polarization and anisotropy are maximum if molecules are still in the downstream direction when they fluoresce. For a thin liquid layer flowing on a solid surface, polarization and anisotropy will be high when the interaction at the interface is low, as the molecular domains [17] will be aligned with the flow [12]. If the interaction between solid surface and liquid increases, they will tend to establish intermolecular forces (anchor), turbulence will develop and generate misaligned molecular domains, and both polarization and anisotropy will decrease.

Reported studies in the literature do not emphasize molecular interfacial phenomena by using high flow velocities, since their samples consist of evaporated LCs, LC cells previously filled, or capillary-filled LCs cells. In this paper relative dynamical Γ_{SL} was evaluated by fluorescence depolarization of liquid thin sheets flowing at high velocities on TN-LCD substrates.

As far as the authors know, this is the first time that θ_c and fluorescence depolarization have been applied to study TN-LCD substrates.

2. Materials and methods

The substrates studied were those used to produce TN-LCDs on the CenPRA/ITI preindustrial assembly line [18]: soda-lime glass (glass), tin dioxide (SnO_2), and rubbed and nonrubbed polyvinyl alcohol (PVA). SnO_2 samples were made of glass coated with 200 nm of tin dioxide [19]. PVA (Carlo Erba) consisted of a 400-nm layer deposited on the SnO_2 surface by spinning a 5% aqueous solution at 2500 rpm for 30 s with a Headway P101 spinner and baking them in an oven at 80°C for 60 min. Then PVA samples were rubbed with 10- μm fibers, always wiping in the same direction and keeping both velocity and pressure constant on the surface.

Table 1
Interfacial data obtained by atomic force microscopy, contact angle (θ_c), polarization (P), and anisotropy (r)

Solid surface	Maximum roughness (nm)	Liquid E7		Liquid MEG		Net P MEG flow (%)	Net r MEG flow ($\times 10^{-2}$)
		θ_c ($\pm 2^\circ$)	$\cos \theta_c$ (± 0.01)	θ_c ($\pm 2^\circ$)	$\cos \theta_c$ (± 0.01)		
Glass	5	21°	0.93	32°	0.85	11.0	7.6
SnO ₂	9	26°	0.90	44°	0.72	11.5	8.0
PVA	2	20°	0.94	28°	0.88	11.3	7.8
PVA	10	14°	0.97	22°	0.93	12.7	8.1
PVA _⊥	10	27°	0.89	35°	0.82	–	–

Liquids: eutectic liquid crystal mixture (E7) and monoethylene glycol (MEG). Substrates: soda-lime glass (glass), tin dioxide (SnO₂), and polyvinyl alcohol (PVA), rubbed and nonrubbed. PVA_{||} and PVA_⊥ represent the data parallel and perpendicular to the rubbing direction, respectively.

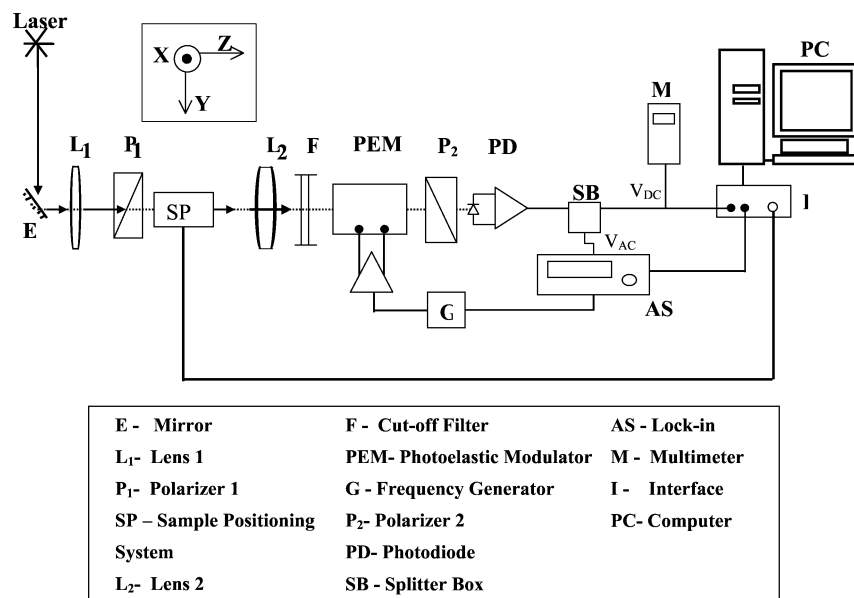

Fig. 1. Experimental setup for polarized laser-induced fluorescence (PLF) to detect fluorescence depolarization.

Two liquids were studied: a eutectic mixture of four twisted nematic liquid crystals (E7) and monoethylene glycol (MEG). E7 (Merck-BDH) is used at the CenPRA/ITI preindustrial TN-LCDs pilot assembly line [18]. The four LCs had similar linear structures: two or three phenyl rings, a polar group [–CN] at one of the extremities, and an alkyl group at the opposite extremity [20]. Rhodamine 6G (fluorescent probe from Lambdaphysik, 99.99% purity) was added to ethylene glycol (99.5% purity, Merck 109621) to make a solution at $1.9 \times 10^{-3} \text{ mol l}^{-1}$.

Three experimental methods were used: atomic force microscopy (AFM) to determine the morphology and roughness of substrates; contact angle of small sessile drops (θ_c) to obtain relative static Γ_{SL} ; PLF of the liquid flow to map fluorescence depolarization and determine the relative dynamic Γ_{SL} .

AFM analysis was performed with a Nanoscope III, Digital Instruments, with J and E type scan heads in contact mode in air.

During contact angle measurements both temperature and pressure were kept constant at $(23.0 \pm 0.1)^\circ\text{C}$ and 1 atm. Drops of $(16 \pm 1) \mu\text{l}$ were formed with a micropipette on substrates and their images were remotely acquired by a Hi-

tachi VM-E230A video camera, with $36\times$ zoom, connected to a PC.

To study dynamical Γ_{SL} , a 100- μm -thick liquid layer flowed on each solid surface at 10° from the vertical, $15.0 \pm 0.5^\circ\text{C}$, and 220 cm s^{-1} average velocity. For rubbed PVA the liquid flow was along the rubbing direction. About 800 mL of liquid was required for these measurements, making it too expensive to use liquid crystal. As static Γ_{SL} for E7 and MEG change similarly with the chemical nature of the substrate (Table 1), MEG was used to simulate E7 liquid-crystal behavior.

The PLF experimental setup (Fig. 1) has previously been described [21]. Briefly, a 514.5-nm laser beam (Coherent Inova70C argon) at 50 mW is deflected by mirror E and focused by lens L1 into the sample, with diameter 0.02 mm. A vertical polarizer, P1, ensures 100% polarization. Fluorescence is collected by lens L2 and passes through a 550-nm cut-off filter F to block laser radiation. Pure fluorescent light enters a photoelastic modulator, PEM (Conoptics 350-50), driven at 600 Hz by a frequency generator, G. The PEM-modulated output light beam is selected by a horizontal polarizer, P2, and reaches the detector PD at a solid angle of 0.02 sr. This homemade detector consists of an OPT 202

Burr–Brown photodiode with active area 5.22 mm^2 and operates as a current-to-voltage converter with four optional sensitivity ranges. The PD output goes into a splitter box, SB, where voltages V_{AC} and V_{DC} are split and then measured respectively by an Ithaco NF 3961B lock-in amplifier, AS, and a Tektronix DMM157 digital voltmeter, M. A two-channel analog-to-digital converter, ADC, acquires V_{AC} and V_{DC} through an interface, I, connected to a PC. Polarization is defined as $P = V_{AC}/(V_{DC} \times f_c)$ where f_c is the correction factor due to optical components birefringence (0.20 for both vertical and horizontal polarized light).

The sample position was varied uniformly in relation to the laser beam direction, using a homemade two-axis translation frame [21] that was remotely controlled by a PC. Flowing systems were scanned vertically and horizontally with resolution $2.5 \mu\text{m}$ in both directions (0.2 mm^2 spatial resolution), with repeatability better than 0.1%. A QBasic program controlled both data acquisition and sample positioning.

3. Results and discussion

AFM showed that soda-lime glass was quite flat, with roughness of about 5 nm and particles at the surface showing a preferential orientation, which may be due to an imperfect cleaning process. Tin dioxide showed 100-nm circular structures and 9 nm roughness, and was rougher than bare glass. With PVA deposition, the surface became more flat due to the filling of irregularities and roughness dropped to 2 nm. Rubbed PVA showed a roughness of 10 nm and irregular undulations along the rubbing direction of about 25 nm height and 100 nm width.

Drops on soda-lime glass, SnO_2 , and PVA had circular top views with diameter about 8 mm. Rubbed PVA drops flowed spontaneously along the rubbing direction after touching the substrate, fitting in an oblong shape (Fig. 2) whose length was about twice their width.

Contact angles for each pair liquid/solid (Table 1) were measured three times at least.

As surface roughness was low for all substrates, it was possible to compare the angles obtained. SnO_2 deposition on glass increased θ_c , pointing up lower chemical affinity between liquids and substrate. Polymer deposition decreased θ_c for both MEG and E7, favoring liquid–solid interaction and increasing Γ_{SL} .



Fig. 2. Drop of MEG on rubbed PVA. It is oblong and stretched along the rubbing direction.

Different angles for rubbed PVA should not be attributed to physical effects such as channel flow due to surface undulations, roughness, or hysteresis. They can only be attributed to chemical interactions that are macroscopically asymmetric. In fact, the spontaneous drop flow cannot be seen as a typical channel flow of fluid mechanics, since irregular undulations along the rubbing direction (shown by AFM) were about six orders of magnitude smaller than the drop diameter. Likewise, it is not expected that the adsorbed monolayer will be aligned due to geometric factors, since the undulation grooves were over two orders of magnitude larger than the liquid molecular dimensions. $\theta_{PVA\perp}$ and $\theta_{PVA\parallel}$ could not correspond to receding and advancing angles, respectively, as the first should decrease instead of increasing, and the second should increase instead of decreasing. Finally, the roughness effect should decrease $\theta_{PVA\perp}$ and not increase it, as measured.

Thus the spontaneous flow on rubbed PVA and the different θ_c for the same sessile drop should be attributed to chemical causes. Interfacial interactions that take place between liquid polar groups (E7 nitriles and MEG hydroxyls) and PVA hydroxyls have strong polar anchoring energies ($\sim 10^0 \text{ erg cm}^{-2}$). Rubbing aligns the polymer chains and, thus, their hydroxyl groups along a preferential direction. The spacing between putative adsorption sites now has two different axes, one parallel and the other perpendicular to the rubbing direction (Fig. 3), producing two different contact angles due to different Γ_{SL} . In fact, using the Young equation, the Γ_{SL} ratio was 1.09 ± 0.02 for E7 and 1.12 ± 0.04 for MEG.

Dynamic relative Γ_{SL} were obtained from maps of fluorescence depolarization acquired along liquid thin layers flowing on the substrates and are shown as polarization and anisotropy. They can be seen as dependent mainly on the chemical nature of the interface, since substrates had roughness below 25 nm whereas maps were acquired with a resolution over 0.7 mm. Table 1 gives net values of P and r at the central region. Figure 4 shows the central region of the polarization maps.

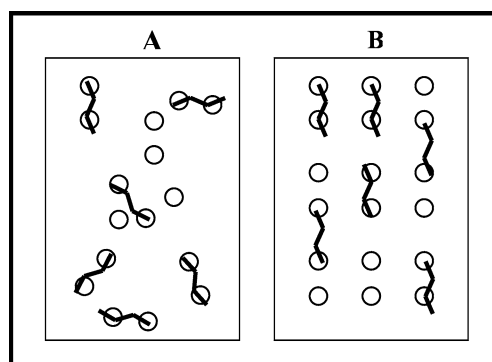

Fig. 3. Scheme of liquid molecules anchoring on surfaces. Circles represent PVA polar groups and sticks represent liquid molecules. (A) Nonrubbed PVA; (B) rubbed PVA.

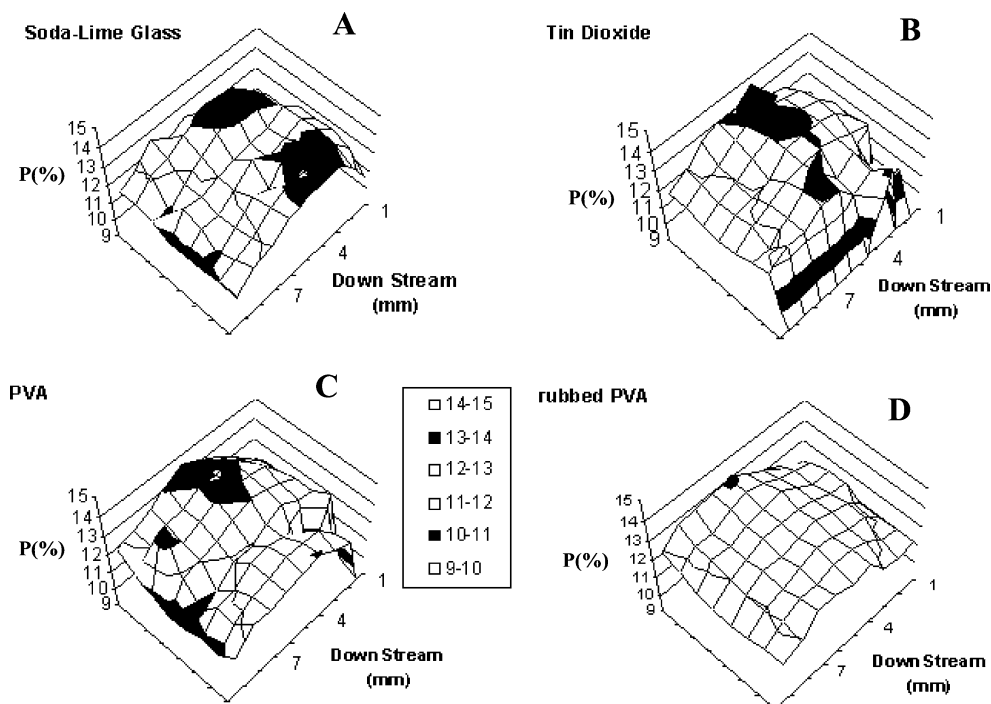

Fig. 4. Fluorescence depolarization data at the flow central region, shown as polarization (P) maps for MEG flowing on (A) soda-lime glass; (B) SnO_2 ; (C) PVA; (D) rubbed PVA.

SnO_2 deposition increased net P and net r (Table 1) as the alignment of molecular domains increased due to weaker intermolecular interaction at the interface.

When PVA was deposited, P and r averages decreased; thus molecular anchoring increased due to stronger dynamic Γ_{SL} . This anchoring process that had no preferential direction (Fig. 3) produced local microturbulence and caused molecular domains that flowed over the interfacial molecular layer to become misaligned.

Flow along the PVA rubbing direction not only had higher P and r averages, but also widened the region where they were homogeneous (Fig. 4D).

The liquid that flowed along the rubbing direction and the polar groups of the substrate were also aligned along the same direction, and molecular domain alignment increased along the stream. Their nanometric scale interaction produced preferential anchoring along the flow direction (Fig. 3B), differently from nondirectional anchoring on nonrubbed PVA. The increase of both polarization and anisotropy is not due to a weaker Γ_{SL} , but to a stronger and highly directional downstream interaction that reduces lateral turbulence and so increases the area where P and r are constant (Fig. 4D). Therefore rubbing increases the region where effective oriented anchoring takes place during the TN-LCD filling process.

4. Conclusions

The relative dynamic interfacial tensions obtained by fluorescence depolarization were in agreement with the static

interfacial tensions obtained by contact angle. SnO_2 deposition led to a decrease in the liquid–solid interfacial interaction that was almost offset by PVA deposition.

PVA rubbing caused axial asymmetry of PVA polar group distribution. Once there are a limited number of polar groups and they establish intermolecular bonds along one direction, the other direction will undergo depletion of polar groups and consequent reduction of putative adsorption sites. Thus intermolecular bonds have a preferential direction to occur and Γ_{SL} increases along the rubbing direction while decreasing along the perpendicular direction.

This asymmetry made the sessile drop on rubbed PVA flow spontaneously along the rubbing direction until it reached an oblong shape. Static contact angles perpendicular and parallel to the rubbing direction were greater and smaller, respectively, than the angle for nonrubbed PVA. During the flow intermolecular bonds will be gradually established along the rubbing direction, as the liquid migrates in a phenomenon similar to capillary flow. The process may be seen as a micro fluid dynamics flow [22] where chemical forces prevail over the physical ones and the flow depends mainly on the boundary layer interactions.

For high-velocity flowing conditions it was also possible to observe that the rubbing increased not only the intermolecular alignment of the anchored monolayer, but also the size of the area where it was more homogeneous.

Thus liquid molecular domains were anchored in a preferential direction (downstream) over a wider region. This may be the cause of the homogeneity increase in TN-LCD displays using rubbed PVA.

The increase of both the preferential direction interfacial tension and the size of the region where homogeneous anchoring occurs, due to rubbing, can explain why the filling direction becomes so important in TN-LCD technology.

Acknowledgments

Conselho Nacional de Desenvolvimento Científico e Tecnológico (CNPq, Brazil) for grants. Ibero-American Network of Liquid Crystal Displays from SubProgram IX: Microelectronics of Program CYTED for their incentive to this work. A.M.V.L. and A.P.S.M. acknowledge their undergraduate research fellowships from PIBIC-CNPq and CNPq. C.C.G. acknowledges a CAPES DPhil scholarship. C.M.Q. acknowledges a senior research scholarship from CNPq.

References

- [1] Werner, IEEE Spectrum 34 (1997) 40.
- [2] M. Geary, J.W. Goodby, A.R. Kmetz, J.S. Patel, J. Appl. Phys. 62 (1987) 4100.
- [3] D.W. Berreman, Phys. Rev. Lett. 28 (1972) 1682.
- [4] G. Barbero, S. Durand, Phys. Rev. A 41 (1990) 651.
- [5] M.B. Feller, W. Chen, Y.R. Shen, Phys. Rev. A 43 (1991) 6778.
- [6] A.W. Adamson, A.P. Gast, Physical Chemistry of Surfaces, Wiley, New York, 1997.
- [7] C.N.C. Lam, R. Wu, D. Li, M.L. Hair, A.W. Neumann, Adv. Colloid Interface Sci. 96 (2002) 169.
- [8] C.W. Extrand, J. Colloid Interface Sci. 248 (2002) 136, doi:10.1006/jcis.2001.8172.
- [9] T.D. Blake, J. De Coninck, Adv. Colloid Interface Sci. 96 (2002) 21.
- [10] S. Daniel, M.K. Chaudhury, Langmuir 18 (2002) 3404.
- [11] F. Brochard-Wyart, P.G. de Gennes, Adv. Colloid Interface Sci. 39 (1992) 1.
- [12] C.M. Quintella, C.C. Gonçalves, I. Pepe, A.M.V. Lima, A.P.S. Musse, J. Braz. Chem. Soc. 12 (2001) 780.
- [13] A.J. Kenyon, A.J. McCaffery, C.M. Quintella, J.F. Winkel, Mol. Phys. 74 (1991) 871.
- [14] A.J. Kenyon, A.J. McCaffery, C.M. Quintella, Mol. Phys. 72 (1991) 965.
- [15] A. Kowski, Crit. Rev. Anal. Chem. 23 (1993) 459.
- [16] J.R. Lakowicz, Principles of Fluorescence Spectroscopy, Plenum, New York, 1983.
- [17] G.J. Juzeliunas, J. Lumin. 46 (1990) 201.
- [18] M.R. Costa, R.A.C. Altafim, A.P. Mammanna, Liq. Cryst. 28 (2001) 1779.
- [19] V. Baranauskas, T.E.A. Santos, M.A. Schreiner, J.G. Zhao, A.P. Mammanna, C.I.Z. Mammanna, Sens. Actuators B 85 (2002) 90.
- [20] I.C. Khoo, Liquid Crystals: Physical Properties and Nonlinear Optical Phenomena, Wiley, New York, 1995.
- [21] C.M. Quintella, C.C. Gonçalves, I. Pepe, A.M.V. Lima, A.P.S. Musse, J. Autom. Methods Manage. Chem. 24 (2002) 31.
- [22] G.M. Whitesides, A.D. Stroock, Phys. Today 54 (2001) 42.